

**FMR SERIES**



“FMR Series” Gerotor Hydraulic Motors are having spool valve design Hydraulic Motors with Roller Stator suitable for Light and Medium Duty Applications

Applications:

- Screw Drives in Injection Moulding
- Conveyor Drives
- Honing head Drives
- Feed Screw Drives in Machine Tools
- Mobile Crane Winches
- Process Automation

	FMR 50	FMR 80	FMR 100	FMR 125	FMR 160	FMR 200	FMR 250	FMR 300	FMR 400
Displacement (cc/rev)	50	80	100	125	160	200	250	300	400
Speed (Max) (rpm)	800	750	600	480	375	300	240	200	150
Torque (Max) Kg.M	8.5	15.5	19.5	24	30.5	33.5	39	25	41
Flow (Max) (Lpm)	40	60	60	60	60	60	60	60	60
Pressure (Max) (Kg/cm <sup>2</sup> )	130	150	150	150	150	130	120	90	80
Output (Max) (HP)	8.0	13.0	13.0	13.0	13.0	12.0	11.0	10.0	8.0
Length 'L' (mm)	139	144	148	152	159	166	175	184	201
Weight (Kg)	6.7	7.0	7.1	7.2	7.6	8.0	8.5	9.0	10.0

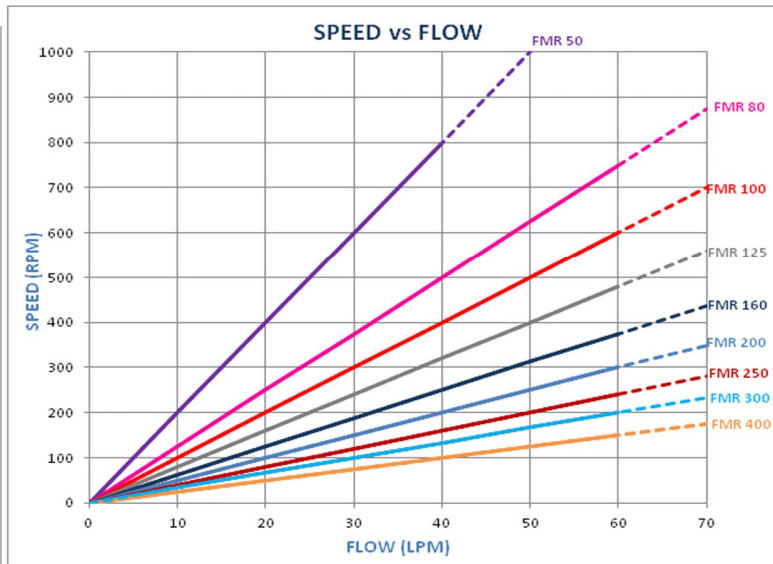
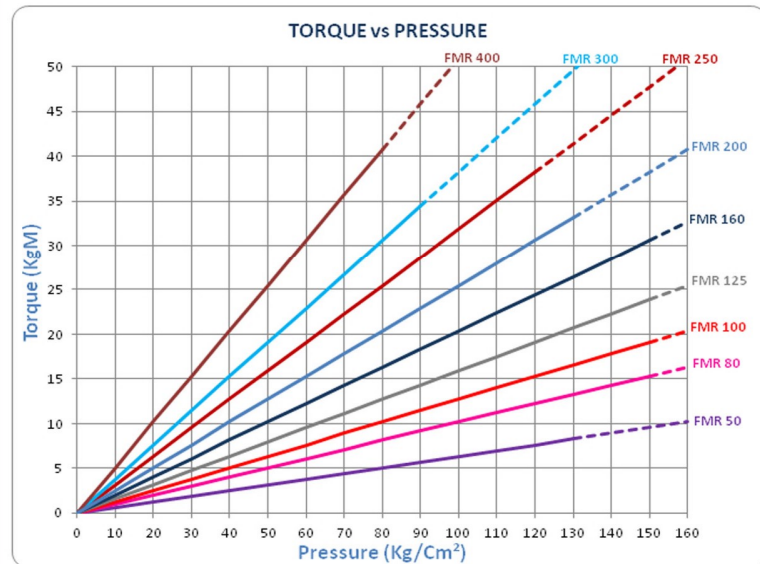
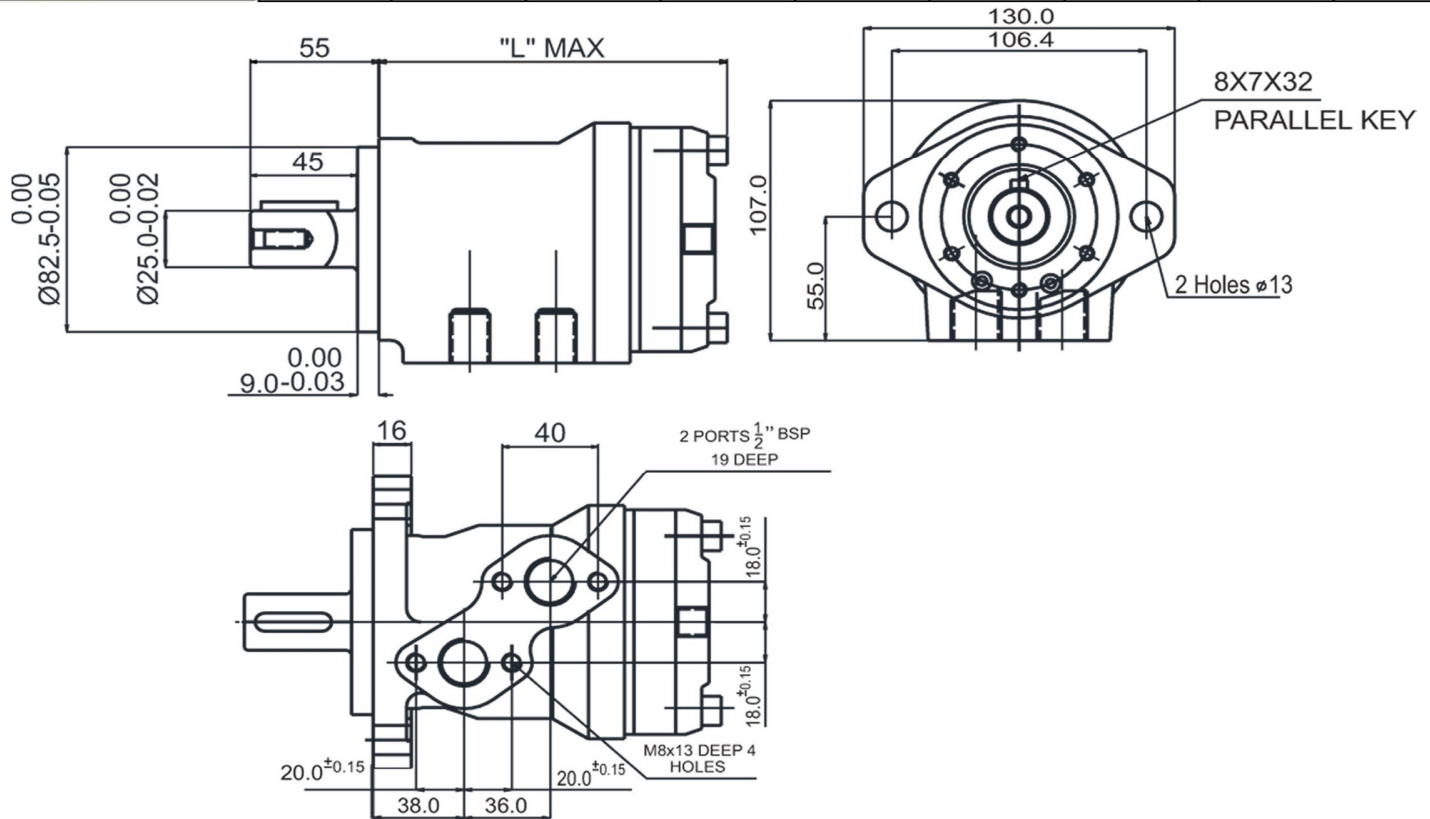

Dotted Lines Indicate Operation in this region is not recommended for continuous application